

Cone Clamping Elements RLK 235 TC

for very high bending moments
premium quality for high centering accuracy



8-1

Dimensions							Technical Data						Bending moments	
Size		B mm	L ₁ mm	L ₂ mm	L ₃ mm	L ₄ mm	Transmissible torque or axial force						M _b max	M _t res at M _b max
d mm	D mm						M ₁ Nm	M ₂ Nm	ΣM Nm	F ₁ kN	F ₂ kN	ΣF Nm		
70	115	88	70	24	58	76	5000	3430	8430	145	98	243	5500	6390
80	125	88	70	24	58	76	6670	4580	11250	169	114	283	7300	8560
90	135	88	70	24	58	76	7500	5150	12650	169	114	283	8200	9630
100	150	96	78	26	61	82	11440	8340	19780	231	169	400	12900	14990
110	160	96	78	26	61	82	12580	9170	21750	231	169	400	14100	16560
120	170	96	78	26	61	82	13730	10010	23740	231	169	400	15400	18070
130	190	111	90	30	71	95	23270	17080	40350	361	264	625	26200	30690
140	200	111	90	30	71	95	25060	18390	43450	361	264	625	28200	33060
150	210	111	90	30	71	95	26850	19700	46550	361	264	625	30300	35340
160	220	111	90	30	71	95	28640	21020	49660	361	264	625	32300	37720
170	240	142	114	40	92	122	47290	30430	77720	561	361	922	50500	59080
180	250	142	114	40	92	122	50070	32220	82290	561	361	922	53500	62530
190	260	142	114	40	92	122	52850	34010	86860	561	361	922	56500	65970
200	270	142	114	40	92	122	69540	44750	114290	702	451	1153	74300	86840
220	290	142	114	40	92	122	76500	49230	125730	702	451	1153	81700	95570
240	310	142	114	40	92	122	100140	64440	164580	842	542	1384	107000	125050
260	330	142	114	40	92	122	108490	69810	178300	842	542	1384	115900	135490
280	365	168	135	45	108	144	141080	97360	238440	1022	702	1724	155000	181190
300	385	168	135	45	108	144	151160	104310	255470	1022	702	1724	166100	194100
320	405	168	135	45	108	144	193480	133520	327000	1226	842	2068	212600	248460
340	425	168	135	45	108	144	239840	165510	405350	1431	983	2414	263500	308020
360	445	168	135	45	108	144	253950	175250	429200	1431	983	2414	279000	326150
380	465	168	135	45	108	144	306350	211410	517760	1635	1123	2758	301900	420630
400	485	168	135	45	108	144	322470	222540	545010	1635	1123	2758	331400	432680
420	505	168	135	45	108	144	338600	233660	572260	1659	1140	2799	360200	444680
440	525	202	167	59	147	178	354720	244790	599510	1659	1140	2799	389700	455570
460	545	202	167	59	147	178	370840	255920	626760	1659	1140	2799	407400	476290
480	565	202	167	59	147	178	386970	267040	654010	1866	1140	2799	425100	497010
500	585	202	167	59	147	178	453480	312940	766420	1866	1282	3148	498200	582410
520	605	202	167	59	147	178	471620	325460	797080	1866	1282	3148	518100	605730
540	625	202	167	59	147	178	489750	337980	827730	1866	1282	3148	538000	629040
560	645	202	167	59	147	178	507890	350500	858390	1866	1282	3148	558000	652280
580	665	202	167	59	147	178	584480	403350	987830	2073	1425	3498	633200	758200
600	685	202	167	59	147	178	604640	417260	1021900	2073	1425	3498	628100	806080

The technical data provided are based on theoretical calculations and the specified screw tightening torques.

Cone Clamping Elements RLK 235 TC

for very high bending moments
premium quality for high centering accuracy

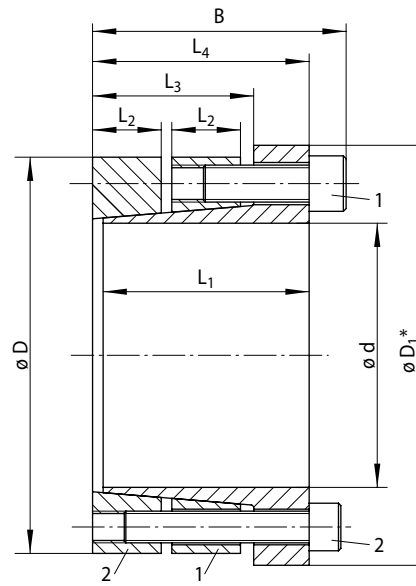

9-1

Dimensions		Contact pressure at				Max. pressure at		Technical Data Clamping screws 1			Clamping screws 2			Weight	Article number
Size		Shaft		Hub		Shaft	Hub	Tightening torque	Number	Size	Tightening torque	Number	Size	kg	
d mm	D mm	P _{W1} N/mm ²	P _{W2} N/mm ²	P _{N1} N/mm ²	P _{N2} N/mm ²	P _W N/mm ²	P _N N/mm ²								
70	115	226	155	137	94	265	161	145	6	M12	83	6	M10	3,62	4204-070501-TC0000
80	125	230	158	147	101	276	177	145	7	M12	83	7	M10	4,02	4204-080501-TC0000
90	135	205	141	137	94	250	167	145	7	M12	83	7	M10	4,44	4204-090501-TC0000
100	150	233	170	156	113	291	194	230	7	M14	145	7	M12	6,02	4204-100501-TC0000
110	160	212	155	146	106	270	186	230	7	M14	145	7	M12	6,46	4204-110501-TC0000
120	170	194	142	137	100	253	178	230	7	M14	145	7	M12	6,88	4204-120501-TC0000
130	190	244	179	167	122	311	213	355	8	M16	230	8	M14	10,56	4204-130501-TC0000
140	200	226	166	158	116	293	205	355	8	M16	230	8	M14	11,22	4204-140501-TC0000
150	210	211	155	151	111	278	199	355	8	M16	230	8	M14	11,92	4204-150501-TC0000
160	220	198	145	144	106	265	193	355	8	M16	230	8	M14	12,46	4204-160501-TC0000
170	240	217	140	154	99	276	196	690	8	M20	355	8	M16	20,58	4204-170501-TC0000
180	250	205	132	148	95	264	190	690	8	M20	355	8	M16	21,52	4204-180501-TC0000
190	260	194	125	142	91	253	185	690	8	M20	355	8	M16	22,58	4204-190501-TC0000
200	270	231	148	171	110	304	225	690	10	M20	355	10	M16	23,38	4204-200501-TC0000
220	290	210	135	159	102	283	215	690	10	M20	355	10	M16	25,64	4204-220501-TC0000
240	310	231	148	179	115	319	247	690	12	M20	355	12	M16	27,90	4204-240501-TC0000
260	330	213	137	168	108	301	237	690	12	M20	355	12	M16	29,85	4204-260501-TC0000
280	365	212	146	163	112	292	224	1200	10	M24	690	10	M20	45,80	4204-280501-TC0000
300	385	198	137	154	106	278	216	1200	10	M24	690	10	M20	48,40	4204-300501-TC0000
320	405	223	154	176	121	318	252	1200	12	M24	690	12	M20	51,40	4204-320501-TC0000
340	425	245	169	196	135	356	285	1200	14	M24	690	14	M20	54,25	4204-340501-TC0000
360	445	231	159	187	129	343	277	1200	14	M24	690	14	M20	57,25	4204-360501-TC0000
380	465	250	173	204	141	365	298	1200	16	M24	690	16	M20	59,00	4204-380501-TC0000
400	485	238	164	196	135	357	294	1200	16	M24	690	16	M20	62,90	4204-400501-TC0000
420	505	226	156	188	130	350	291	1200	16	M24	690	16	M20	65,35	4204-420501-TC0000
440	525	165	114	138	95	234	196	1200	16	M24	690	16	M20	82,70	4204-440501-TC0000
460	545	158	109	133	92	226	191	1200	16	M24	690	16	M20	85,70	4204-460501-TC0000
480	565	151	104	128	89	220	187	1200	16	M24	690	16	M20	91,00	4204-480501-TC0000
500	585	163	113	139	96	241	206	1200	18	M24	690	18	M20	94,00	4204-500501-TC0000
520	605	157	108	135	93	234	201	1200	18	M24	690	18	M20	98,00	4204-520501-TC0000
540	625	151	104	130	90	228	197	1200	18	M24	690	18	M20	101,00	4204-540501-TC0000
560	645	146	100	126	87	223	194	1200	18	M24	690	18	M20	104,00	4204-560501-TC0000
580	665	156	108	136	94	241	210	1200	20	M24	690	20	M20	108,00	4204-580501-TC0000
600	685	151	104	132	91	232	204	1200	20	M24	690	20	M20	111,00	4204-600501-TC0000

The technical data provided are based on theoretical calculations and the specified screw tightening torques.

Hub arrangement

For Cone Clamping Elements with a fixed backstop point, the hub must be positioned as shown in figure 14-1.

For Cone Clamping Elements without a fixed backstop point, the hub must be positioned as shown in figure 14-2. In this case, it is assumed for practical purposes that the screw heads of the Cone Clamping Element are flush with the hub on one side

Required hub width

The hub width N_A used in the application must not be smaller than the load-bearing hub width L_1 .

Required hub outer diameter

The hub outer diameter K_A used in the application must not be smaller than the required hub outer diameter K_{min} . The required hub outer diameter K_{min} can be calculated approximately using the hub width N_A used in the application and the corresponding yield strength R_e of the hub material as follows:

$$K_{min} = 1,2 \cdot D \cdot \frac{H - 1,25}{H - 3}$$

$$\text{with } H = \left(\frac{R_e}{1,27 \cdot P_N} \cdot \frac{N_A}{L_T} \right)^2$$

Required yield strength of the hub material

For a given hub width N_A and a given hub outside diameter K_A , the yield strength R_e of the hub material must be greater than the equivalent stress σ_v in the hub.

$$\sigma_v = 1,27 \cdot P_N \cdot \frac{L_T}{N_A} \cdot \frac{\sqrt{3 + C_N^4}}{1 - C_N^2}$$

$$\text{with } C_N = \frac{D}{K_A}$$

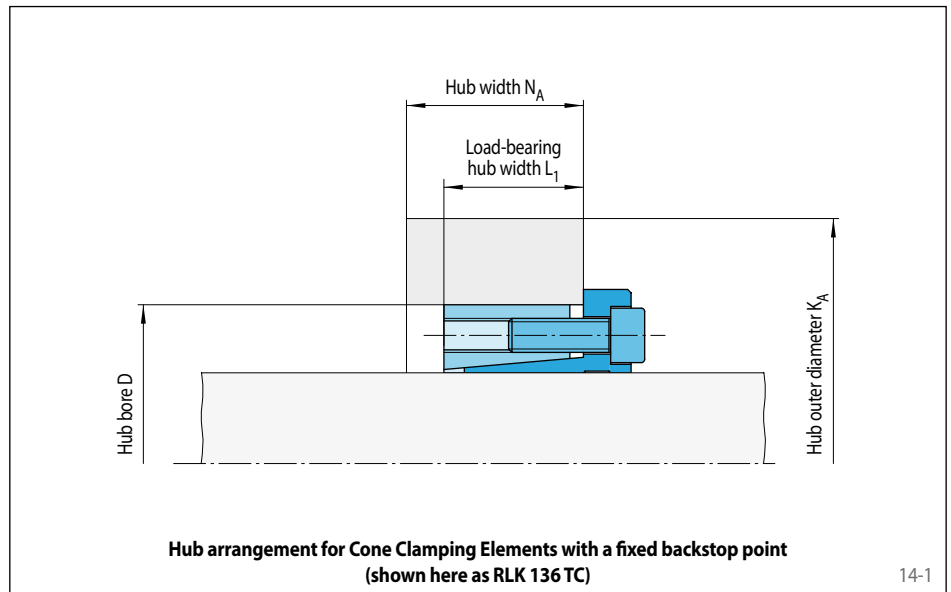

14-1

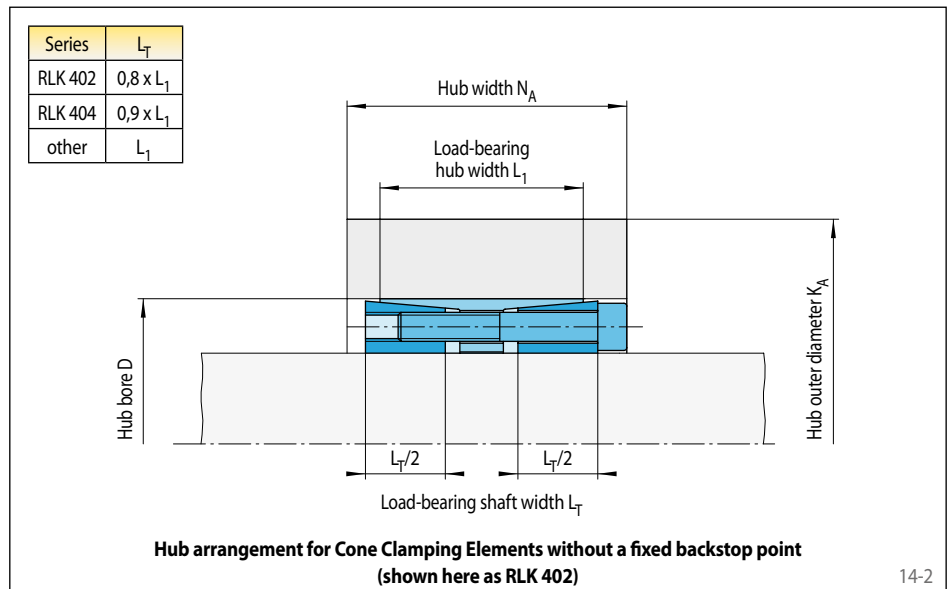

14-2

Formula symbols

C_N = Auxiliary value without unit

D = Hub bore according to table [mm]

H = Auxiliary value without unit

K_A = Hub outer diameter used in the application [mm]

K_{min} = Required hub outer diameter according to calculation [mm]

L_1 = Load-bearing axial hub width according to table [mm]

L_T = Load-bearing shaft width [mm]

N_A = Hub width used in the application [mm]

P_N = Contact pressure at the hub according to table [N/mm²]

R_e = Hub material yield strength [N/mm²]

σ_v = Equivalent stress in the hub [N/mm²]

Clamping screw tightening torque

The tightening torque M_S listed in the tables must be achieved during assembly and must not be exceeded by more than 10%. If the indicated tightening torque M_S is not achieved,

the transmissible torque or axial force, as well as the contact pressures at the shaft and at the hub will be proportionally reduced compared to the values listed in the tables for M or F as

well as for P_W and P_N . When the indicated tightening torque M_S is undercut by more than 30%, please contact us.

Simultaneous transmission of torque and axial force

The transmissible torques M which are shown in the tables apply for axial forces $F = 0$ kN and conversely, the indicated axial forces F apply to torques $M = 0$ Nm. If torque and axial force are to be transmitted simultaneously, the transmissible torque and the transmissible axial force are reduced compared to the values listed in the tables for M and F.

For a given axial force F_A , the reduced torque M_{red} is calculated as:

$$M_{red} = \sqrt{M^2 - (F_A \cdot \frac{d}{2})^2}$$

For a given torque M_A , the reduced axial force F_{red} is calculated as:

$$F_{red} = \frac{2}{d} \sqrt{M^2 - M_A^2}$$

Design of shaft and hub

The transmissible torques or axial forces listed are subject to the following tolerances, surface characteristics and material requirements. Please contact us in the case of deviations.

Tolerances

- h8 for shaft diameter d
- H8 for hub bore D

Surfaces

Average surface roughness at the contact surfaces between the shaft and the hub bore:
 $R_z = 10 \dots 25 \mu\text{m}$.

Materials

The following apply to the shaft and the hub:

- E-module $\geq 170 \text{ kN/mm}^2$

Installation

Please request our installation and operating instructions Cone Clamping Elements.

Formula symbols

d = Shaft diameter according to table [mm]

F = Transmissible axial force according to table [kN]

F_A = Maximum actual application axial force [kN]

F_{red} = Reduced axial force [kN]

M = Transmissible torque according to table [Nm]

M_A = Maximum actual application torque [Nm]

M_{red} = Reduced torque [Nm]

M_S = Screw tightening torque according to table [Nm]

P_N = Contact pressure at the hub according to table [N/mm²]

P_W = Contact pressure at the shaft according to table [N/mm²]